

NEW **BEUTHLING**

OWNER'S & PARTS MANUAL

B155

**RIDE-ON VIBRATORY COMPACTOR - 1 1/2 TON
GASOLINE & DIESEL ENGINES**

SERIAL NUMBER 155-NB23-0001 & UP

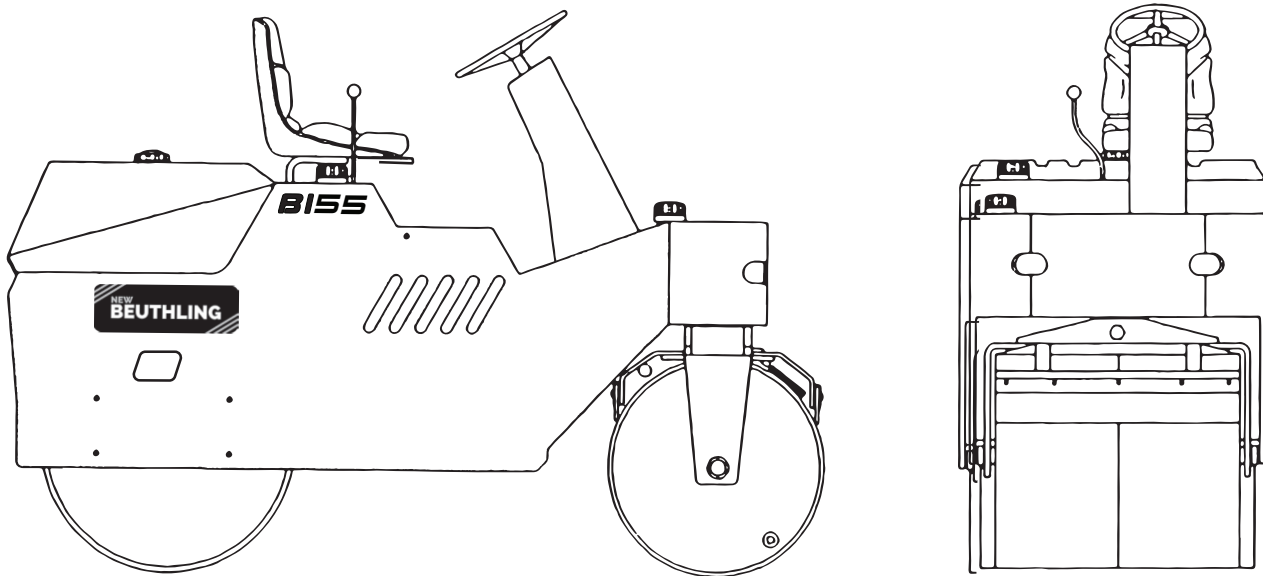

WARNING! READ THIS MANUAL AND  AEM ROLLER COMPACTOR SAFETY MANUAL BEFORE OPERATING OR SERVICING YOUR MODEL B155.

TABLE OF CONTENTS

OPERATION	4-7
MAINTENANCE.....	7-8
DECALS, OPERATION & MAINTENANCE	9-10
FRONT END ASSEMBLY	11-12
REAR DRUM ASSEMBLY	13
DRUM SPRAY SYSTEM	14
ELECTRICAL SYSTEM w/HONDA ENGINE	15-16
ELECTRICAL SYSTEM w/KUBOTA DIESEL ENGINE	17-18
KUBOTA DIESEL ENGINE & RELATED COMPONENTS.....	19-20
HYDRAULIC DRIVE SYSTEM	21-22
MISCELLANEOUS COMPONENTS	23-25
COVERS, SCRAPERS, COCOA MATS	26
SPECIFICATIONS.....	27
WARRANTY	28
MACHINE IDENTIFICATION INFORMATION	BACK COVER

NOTE:

FOR ALL INQUIRES PLEASE INDICATE:

NEW BEUTHLING MODEL _____

NEW BEUTHLING SERIAL NUMBER _____

ENGINE MAKE & MODEL _____

ENGINE SPEC NUMBER _____

MODEL & SERIAL NUMBER PLATE IS LOCATED ON FRONT MAIN FRAME

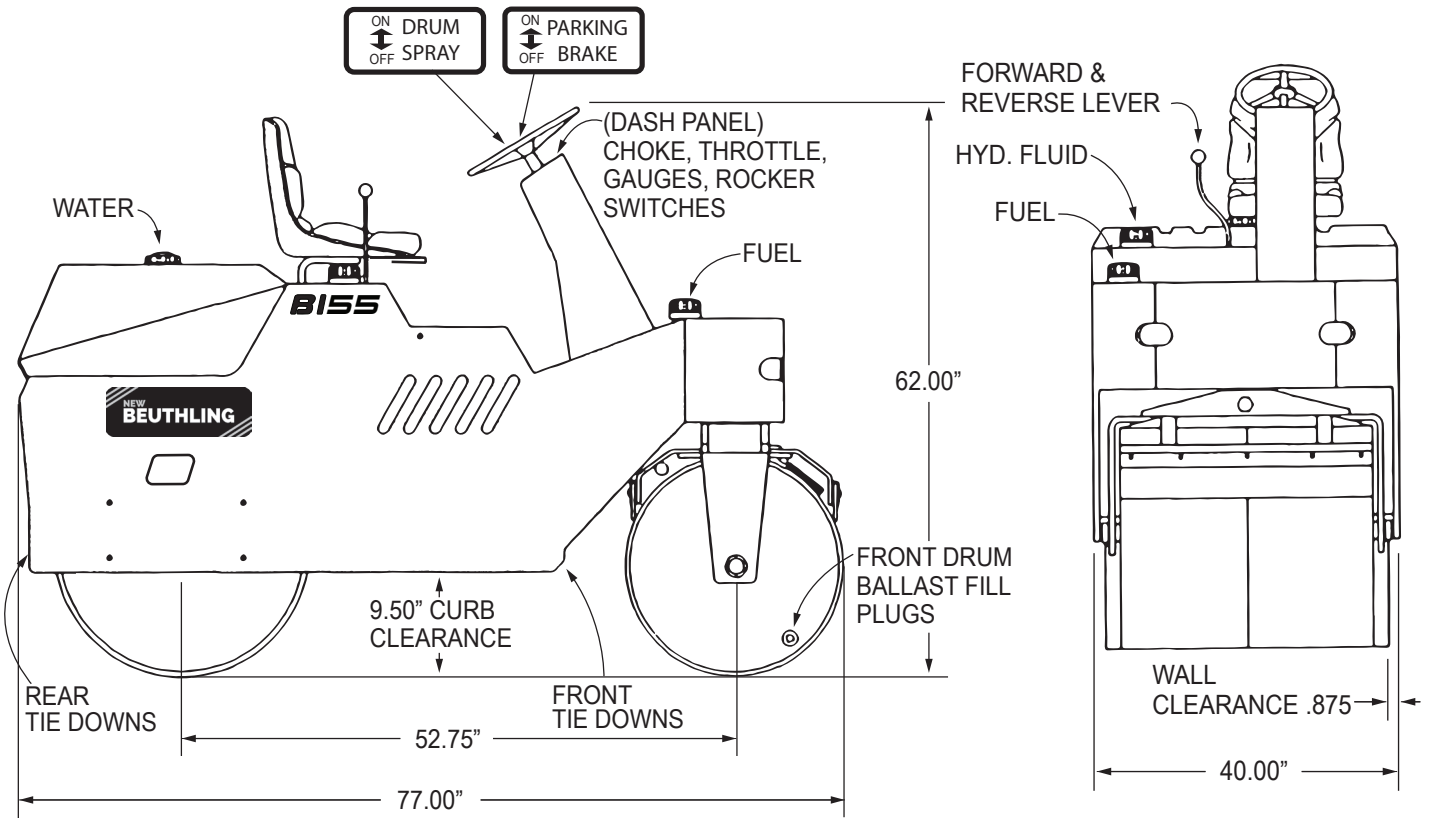

SAFETY WARNING

- BEFORE OPERATING UNIT, READ AND UNDERSTAND "OWNER'S MANUAL."
- IT IS THE CUSTOMER'S RESPONSIBILITY TO SUPERVISE, TRAIN AND EDUCATE THEIR EMPLOYEES OR ANY OTHER USER OF THIS EQUIPMENT FOR PROPER OPERATION, MAINTENANCE AND SAFETY.
- KEEP HANDS AND FEET CLEAR WHEN UNIT IS RUNNING OR MOVING.



OPERATING OR PARKING THIS UNIT ON INCLINES, HILLS, RAMPS OR NEAR THE EDGE OF A WORK SURFACE MAY BE DANGEROUS AND CAUSE THIS UNIT TO BECOME UNSTABLE OR ROLLOVER.



ALWAYS BE IN CONTROL OF YOUR UNIT

FAILURE TO OBEY SAFETY WARNINGS MAY RESULT IN SERIOUS INJURY TO OPERATOR OR OTHERS.

OPERATION



WARNING:

Read this manual and the **AEM** "Roller - Compactor Safety Manual", supplied with the machine BEFORE starting, operating, or servicing the machine.

Before starting engine make certain control lever is in "NEUTRAL" (center) position. The transmission MUST be in the "NEUTRAL" position for the engine to be started. A neutral start switch has been included within the electrical system. The brake rocker switch is located on the console dash panel and is "ON" (or brake applied) when rocker switch is in UP position and "OFF" when rocker switch is in DOWN position. When brake rocker switch is "ON", red indicator light is LIT and ALARM buzzer is SOUNDING (IF EQUIPPED).



WARNING:

The machine MUST NOT move, and ANY time, when the secondary/parking brake rocker switch is in the "ON" (up) position.

DO NOT operate the machine, if the machine will MOVE when the secondary/parking brake rocker switch in "ON".

NEVER drive the machine with the secondary/parking brake rocker switch "ON".

When starting, if so equipped, and not previously done, unlock the locks securing the floor and dash covers. Move the dash cover to the stowed position.

Continued next page

If so equipped with ROPS, IMMEDIATELY, after being seated, place the seat belt across the lap and SECURELY insert the metal end into the belt buckle. TIGHTEN the belt, AGAINST the body, by pulling on the loose end of the belt.

Move the engine speed throttle control to the LOW (down) engine idle speed position. Pull the engine choke knob to the “choke” (up) position, if the engine is cold.

Turn the ignition switch key to the START position. Crank and start the engine. If used, push the choke knob “in” as the engine warms. Put the engine throttle speed (RPM) control in the desired engine speed position and turn the throttle control handle clockwise to “lock” in position.

CAUTION:

If the engine does NOT start within ten (10) seconds of continuous cranking, turn the ignition key switch to the “OFF” position and wait at least thirty (30) seconds. This will allow the starter motor time to cool. Try starting the engine again. Do NOT increase the speed of the engine ABOVE the LOW rpm for a period of one (1) minute, to allow the hydraulic oil to reach operating temperature.

WARNING:

Do NOT put the engine throttle speed (RPM) handle in the “FULL” engine speed position when the machine is being run in a confined area, or is near ANY object.

Check operation of ALL gauges and instruments. Check the operation of ALL other optional equipment, such as rotating beacon and work lights, if so equipped. The machine is put into motion by moving the control lever in the direction of the travel desired. PUSHING the lever in the FORWARD direction will select a FORWARD direction of machine travel. PULLING the lever in the BACKWARD direction will select the REVERSE direction of the machine travel. If so equipped, note that the back up alarm system sounded when the control lever moved within the REVERSE position. The machine travel speed is proportional to the amount of the control lever movement, UNTIL full lever travel has been reached, in EITHER direction. The control lever should be moved slowly from one direction through neutral to the opposite direction. The procedure utilizes the hydraulic system’s DYNAMIC BRAKING capability to bring the machine’s weight to a complete stop, at neutral, before going in the opposite direction. This procedure allows the transmission system and engine to slow the machine to a stop.

If it is noticed that the engine power decreases when the control lever is fully advanced during a heavy pull, move the control lever back to increase power and decrease “engine lugging”.

WARNING:

Slowing or stopping of machine during LEVEL surface operation is done by moving the directional/speed control lever TOWARD, and then TO the NEUTRAL position. Slow, or stop, the machine on a SLOPE, by moving the directional/speed control lever to the direction OPPOSITE the direction of machine travel.

If the machine speed can NOT be controlled through the use of dynamic braking, use dynamic braking AND the secondary/parking brake system to slow, and then stop the machine.

The secondary/parking brake system MUST be used to hold the machine in a “stopped” condition at ALL times. The transmission system will NOT hold the machine in a “stopped” condition.

STARTING DIESEL ENGINE

IMPORTANT:

- Do not use ether or any starting fluid for starting the engine, or severe damage will occur.
- When starting the engine after a long storage (of more than 3 months), first set the stop lever to the “STOP” position and then activate the starter for about 10 seconds to allow oil to reach every engine part.

1. Set the fuel cock to “ON” (on engine).

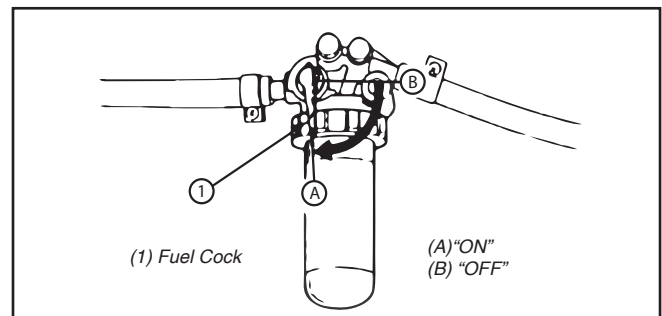

2. Move directional/speed control lever to “Neutral” position.

3. Set the throttle handle at more than half “OPERATION”.

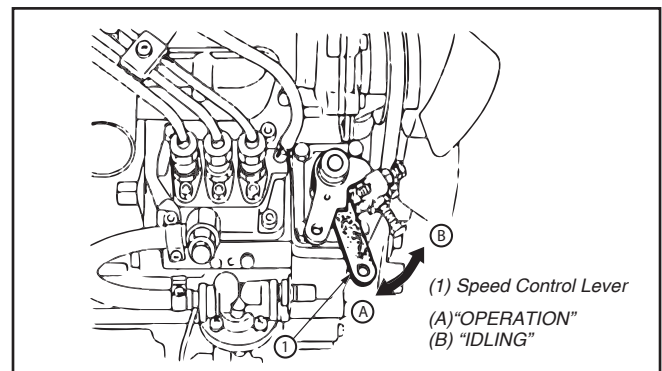

4. Insert the Ignition key into the key switch and turn it “ON”.

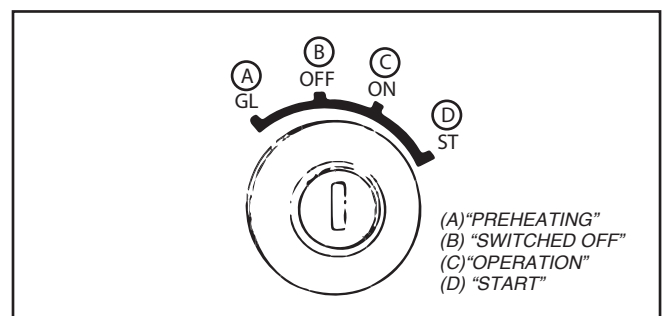

5. Turn the Ignition Key to the “PREHEATING” position to allow the glow lamp timer indicator to illuminate.

COLD WEATHER STARTING DIESEL

If the ambient temperature is below -5°C (23°F) and the engine is very cold, start it in the following manner:

Take steps (1) through (4) left.

Turn the Ignition Key to the “PRE-HEAT” position and keep it there for a certain period mentioned below.

IMPORTANT:

- Shown below are the standard preheating times for various temperatures. This operation, however, is not required, when the engine is warmed up.

Temperature	Preheating Time
Over 10°C(50°F)	About 6 sec.
Below -5°C(23°F)	About 10 to 15 sec.

NOTE:

(with lamp timer in use)

- The glow lamp goes out in about 6 seconds when the lamp timer is up. Refer to this for pre-heating. Even with the glow lamp off, the glow plug can be pre-heated by turning the Ignition Key switch to the “PREHEATING” position.

6. Turn the Ignition Key to the “START” position and the engine should start. Release the Ignition Key immediately when the engine starts.

7. Check to see that the oil pressure gauge and battery gauge are indicating properly, if not immediately stop the engine, and determine the cause.

(See “CHECKS DURING OPERATION” in “Operating the Engine” Section of Kubota Operators Manual.)

NOTE:

- If the oil pressure drops below normal immediately stop the engine and check;
 - If there is enough engine oil.
 - If the engine oil has dirt in it.
 - If the wiring is faulty.
- If the engine does not catch or start at 10 seconds after the Ignition Key is set at “START”, wait for another 30 seconds and then begin the engine starting sequence again. Do not allow the started motor to run continuously for more than 20 seconds.

8. Warm up the engine at medium speed without load.

IMPORTANT:

- Do not allow the starter motor to run continuously for more than 20 seconds.
- Be sure to warm up the engine not only in winter, but also in warmer seasons. An insufficiently warmed-up engine can shorten its service life.
- When there is fear of temperature dropping below -15°C (5°F) detach the battery from the machine, and keep it indoors in a safe area, to be reinstalled just before next operation.

STOPPING DIESEL ENGINE

1. Move directional/speed control lever to **neutral position**.
2. Set engine throttle hand to **idle** position, (Down)
3. Set **parking brake switch** to **ON** position.
4. Turn **ignition key** counterclockwise to **off** position and remove from switch. Spring actuated brakes **will not** be applied with ignition switch on.

EMERGENCY SHUTDOWN PROCEDURE:

(Diesel Engine)

1. Move directional/speed control lever to **neutral position**.
2. Turn **ignition key** counterclockwise to **Off Position** and remove from switch. Parking Brake is spring actuated when engine is stopped and Ignition Switch is turned off.

See Kubota Engine Owners Manual for additional details on engine operation.

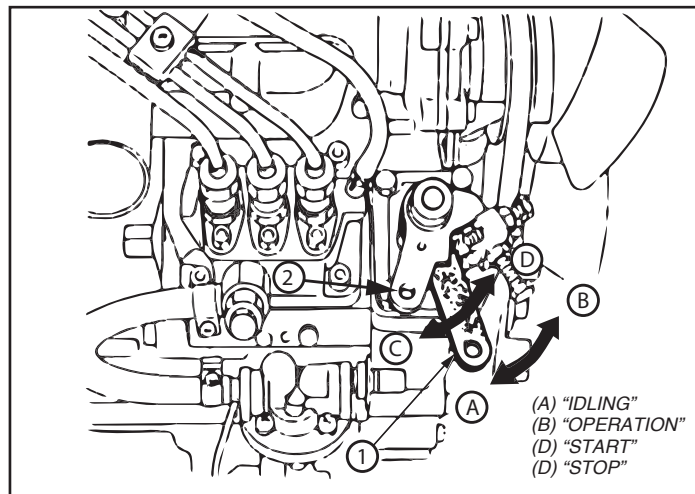

(1) “Speed Control Lever”
(2) “Engine Stop Lever”

DYNAMIC BRAKING

Hydrostatic drive motor in rear drum provides hydraulic dynamic braking when the directional/speed control lever is moved to neutral.

SECONDARY / PARKING BRAKE:

Failsafe, mechanical disc brakes in the hydrostatic drive motor are spring actuated when engine is stopped. Brake is hydraulically released when engine is started. Manual parking brake switch on console controls solenoid hydraulic valve which actuates, and releases secondary/parking brake when engine is running. Manual switch in "OFF" position releases brakes, and in "ON" position actuates brakes.



WARNING:

Do Not try to move machine with secondary parking brake engaged. Backup pressure of hydraulic system with low engine RPM's may have adverse affects on engine and hydraulic system if this happens.

DRUM SPRAY SYSTEM

The pressurized drum spray system will help keep both drums clean when compacting asphalt. Fill the water tank with clean water. Located by the seat is the spray valve. Open valve, by moving the valve handle, until the desired flow rate is obtained. Put the drum spray system control switch in the "ON" position (located on dash). NEVER run the system dry.

A full width cocoa mat is located on each drum and is used in combination with the drum spray system to help keep the drum surface wet and clean.

DRUM SCRAPERS

Both the front and rear drums are equipped with full width, adjustable rubber scrapers which are mounted ahead of, and behind each drum. These scrapers are designed to help keep large pieces of material from clinging to the drums when traveling in either direction. The scrapers must remain adjusted against the surface of the drums at all times.

DRUM BALLAST

This machine is designed for use with or without liquid ballast in the front drums only.

If water ballast is used in temperatures below freezing, use 30% alcohol in water. If fuel oil is used, allow 10% for expansion. A pipe plug is located in each front roller for filling and draining purposes, be sure to fill or drain both front drums.

MACHINE TRANSPORT

When the machine is being moved by truck or trailer, use SOLID wood blocking. Use SOLID wood blocks in front, and at the rear, on EACH side of EACH drum. Four (4) tie-down areas are provided and are to be used, with the blocking, to secure the machine to the truck or trailer bed when transporting the machine. Secure all fill caps and covers before transporting.

MAINTENANCE



WARNING:

DO NOT operate machine if any part is not in proper operating condition or is missing. Always remove key from switch when performing maintenance (engine off), leaving equipment unattended or when equipment is not in use.

ENGINE (GASOLINE)

Daily check the engine lubrication oil level in the crankcase. The engine lubrication oil MUST be kept at a level ABOVE the "ADD" mark but NOT ABOVE the "FULL" mark on the engine lubrication oil dipstick. A low oil warning indicator "Red" light is located on dash. Check engine oil when lit. Check the engine inlet air cleaner condition and remove and replace as needed.



CAUTION:

See the "Engine Operation and Maintenance Instruction Manual", published by the Honda or Kubota Engines for approved, correct engine component inspection and maintenance periods and/or procedures.

HYDRAULIC SYSTEM

After a new machine has run FIVE (5) hours, the oil filter should be changed. This is to rid the system of any trapped contamination from factory assembly. ANYTIME the filter has been changed, IDLE engine for three (3) minutes with control lever in neutral. At the end of this running period SLOWLY engage forward to reverse. This allows fluid to replace the air in the pump area introduced into the system with the filter change. IF THIS PROCEDURE IS NOT FOLLOWED partial or complete failure of the pump will result.

Check hydraulic fluid daily, change fluid and filters every 250 hours or yearly, sooner if conditions warrant, i.e. extreme dust or condensation. The B155 is equipped with a 8 quart oil reservoir – when changing or adding fluid, use AW ISO 32 Fluid or Equivalent. To prevent any foreign matter from entering the tank, extreme care should always be used when removing fill cap. Fluid is at proper level when seen at the "middle" of the screen in the fill neck. Never fill reservoir to overflowing.

DIRECTIONAL CONTROL LEVER

Lubricate the directional control lever and cable assembly exposed, and pivoting part areas, with EP-2 chassis grease. NO zerk fitting is found on the directional control level and/or cable assembly. Inspect the mechanical condition of the control lever and cable assembly. It must NOT be loose, damaged, or bind within the lever, or cable. Repair, or replace, the direction control lever and/or cable assembly if any damage is noted.

FRONT DRUMS

Several times per year, lift the front drums and check for any side movement (end play) of the drums, through the tapered roller bearings. If needed, adjust the movement by loosening the two (2) set screws found on each end of the front axle and tightening the Axle bolts (having grease zerks) to obtain correct end play. Retighten the set screws.

DRUM SCRAPERS/COCOA MATS

Check the condition and adjustment of all four (4) rubber scrapers, if worn beyond adjustment replace with new. NOTE: Rubber scrapers can be removed and flipped to opposite side to extend life. Check and replace both cocoa mats when worn or damaged. Never allow steel pans to come in contact with drum. Front and rear cocoa mats pans are designed to pivot away from drums when not in use.

BEARINGS

Lubricate each of the four (4) front axle bearings through the one (1) zerk fitting found at the left, and (1) zerk on the right end of the front axle shaft with EP-2 chassis grease. Use enough grease through zerk fitting to purge old grease on inner bearings. All bolts, drive coupling set screws and collar set screws of bearings, should be checked during each periodical maintenance check and lubrication activity.

See lubrication chart in this manual and under center floor cover for complete bearing lubrication.

DRUM SPRAY SYSTEM

The water should be drained from the system when freezing temperatures are expected. Remove drain plug Item (13) to drain tank. Remove Hoses Items (9) and (24) to drain pump and valves. See Drum Spray System Diagram page 14.

ELECTRICAL SYSTEM

This system is 12-volt, during engine and other system maintenance inspections, check the electrical wiring for correct routing and support. Inspect the wires for loose terminal connections, cracks or wear in the wiring insulation and for corrosion.



WARNING:

BATTERY EXPLOSION CAN OCCUR IF A BATTERY IS SHORTED. ALWAYS disconnect BOTH the positive (+) AND the negative (-) battery cables from a battery, BEFORE ANY repair procedures are done to the electrical wiring or components. DO NOT weld on machine unless battery is disconnected and removed.

A thirty (30) amp circuit breaker has been installed in the electrical circuit. It is located under the dash. If a circuit overload occurs, the circuit breaker will reset automatically every ten (10) seconds, or until the cause of the overload has been located and corrected.

Gasoline units have three functions monitored by gauges on the dash panel. These functions are: VOLTMETER, HOURMETER and FUEL GAUGE. Diesel units have five functions monitored by gauges on the dash panel. These functions are: ENGINE OIL PRESSURE, ENGINE WATER TEMPERATURE, VOLTMETER, HOURMETER and FUEL GAUGE.

For indicator light functions refer to Operation, pages 1-4. NEVER attempt to disconnect the hourmeter. Engine and machine operating hours are essential for proper machine maintenance.

LUBRICATION CHART

MODEL B155

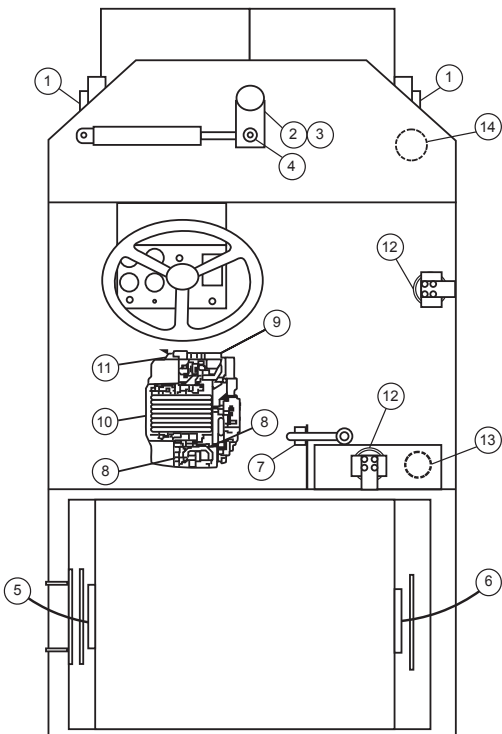

Ref No.	Lubrication Point					Types of Lubricant	Lub. Fitting
		DAILY	WEEKLY	MONTHLY	250 HOURS		
1	Front Axel Bearings		•			EP-2 Chassis Lub.	Yes (2)
2	Front Pivot Tube		•				Yes
3	Oscillating King Pin		•				Yes
4	Steering Cylinder Rod End		•				Yes
5	Vibe Bearing LH			•			Yes
6	Vibe Bearing RH			•			Yes
7	Control Lever		•				No
8	Engine Crankcase/Dipstick	✓				See Engine Manual	No
9	Engine Oil Filter			•			No
10	Engine Air Cleaner	✓		•			No
11	Fuel Filter			•		No	
12	Hydraulic Oil Filters			•		Replace Filter Element	No
13	Hydraulic Oil Reservoir	✓		•		Sunco AW ISO 32 or Equivalent 12 U.S. qts.	No
14	Fuel Tank	✓				3 U.S. Gal.	No

✓ Check • Lub. or Change

See Owner's Manual For Further Details

DECALS, OPERATION & MAINTENANCE



380-003/132

SEE OPERATION & MAINTENANCE MANUAL FOR ALL ADJUSTMENTS & SERVICE

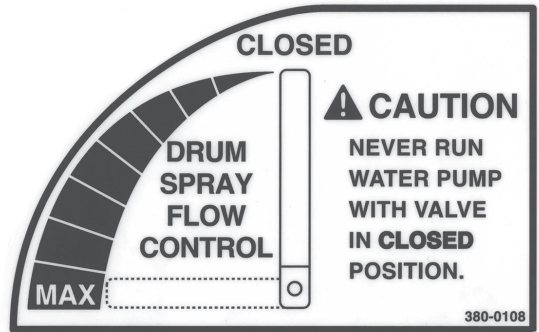

IMPORTANT IN HANDLING RADIATOR

1. Prior to use, check the water and replenish it. Don't Forget This.
2. When the overflow pipe starts emitting vapor, check the water and replenish it.
3. When dirt and insects are trapped in the screen, remove the screen and clean it.
4. Check and clean the Fins periodically. Fins clogged with dirt and mud will increase the consumption of water.
5. When the engine is put to continuous use under the blazing sun, inspect the water more often than usual.
6. For further details read the Operator's Manual.

16478-88232

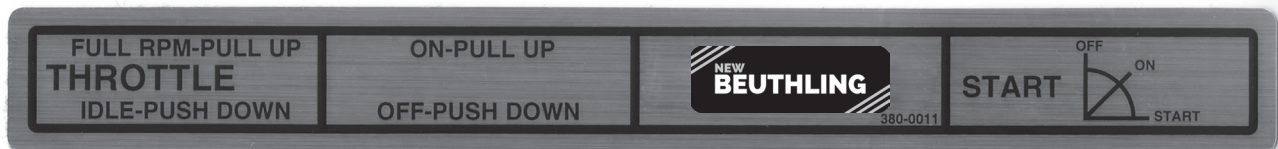
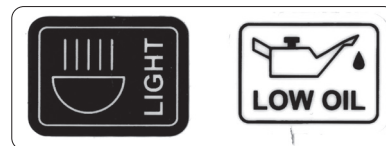

FILTER CHART

Honda GX 630 Gasoline Engine

Oil Filter	200-0400
Fuel Filter	200-0402
Air Filter Element	200-0401
Hyd. Oil Filter	130-0002

FILTER CHART

Kubota Z602 Diesel Engine

Oil Filter	205-0010
Fuel Filter	205-0011
Air Filter Element	205-0246
Hyd. Oil Filter	130-0002

DECALS, OPERATION & MAINTENANCE

CAUTION

DO NOT PUSH OR PULL UNIT.
MAY CAUSE DAMAGE TO
HYDRAULIC SYSTEM.

TO START CONTROL, LEVER
MUST BE IN NEUTRAL.

OPERATION WARNING

EQUIPPED WITH TRANSMISSION BY-PASS VALVE
NORMAL OPERATION - CLOSE VALVE CW (CLOCKWISE)
FREEWHEEL - OPEN VALVE 180°CCW (COUNTER CLOCKWISE)

 NORMAL OPERATION
(CLOSED)

FREEWHEEL (OPEN)

CAUTION | **ROTATING PARTS**

WARNING | **HOT AREA**

↓

NO STEP

RECOMMENDED HYDRAULIC FLUIDS

- USE H.D. ISO-32 HYD. FLUID OR EQUIVALENT
- FILL TO MIDDLE OF SCREEN ONLY
- CHECK HYDRAULIC FLUID DAILY
- CHANGE FLUID & FILTER EVERY 250 HRS. (SOONER IF CONDITIONS WARRANT)

SAFETY WARNING

- BEFORE OPERATING UNIT, READ AND UNDERSTAND "OWNER'S MANUAL."
- IT IS THE CUSTOMER'S RESPONSIBILITY TO SUPERVISE, TRAIN AND EDUCATE THEIR EMPLOYEES OR ANY OTHER USER OF THIS EQUIPMENT FOR PROPER OPERATION, MAINTENANCE AND SAFETY.
- KEEP HANDS AND FEET CLEAR WHEN UNIT IS RUNNING OR MOVING.

 OPERATING OR PARKING THIS UNIT ON INCLINES, HILLS, RAMPS OR NEAR THE EDGE OF A WORK SURFACE MAY BE DANGEROUS AND CAUSE THIS UNIT TO BECOME UNSTABLE OR ROLLOVER.



ALWAYS BE IN CONTROL OF YOUR UNIT

FAILURE TO OBEY SAFETY WARNINGS MAY RESULT IN SERIOUS INJURY TO OPERATOR OR OTHERS.

380-0027 REV.

FORWARD

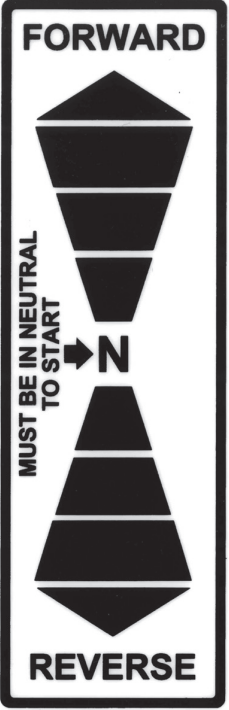

REVERSE

NEW BEUTHLING



AMERY, WISCONSIN

FRONT END ASSEMBLY

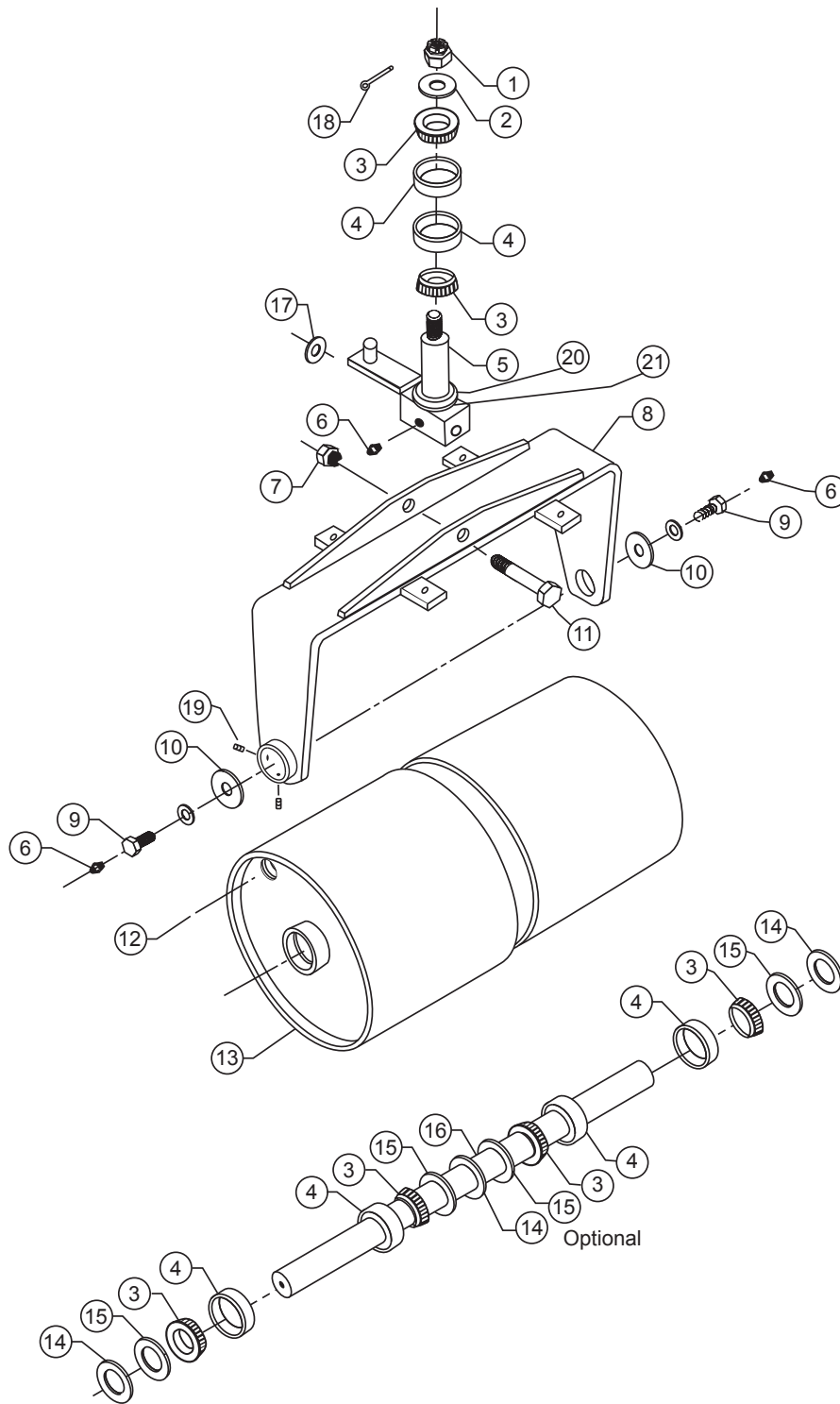

FRONT END ASSEMBLY

Item No.	Part No.	Description	Qty.
1	609-0076	Hex Slotted Nut	1
2	000-1043	Washer – King Pin	1
3	300-0001	Bearing Cone.	6
4	300-0002	Bearing Cup.	6
5	000-2121	King Pin (complete with 000-2014 and 000-2015)	1
6	370-0001	Grease Fitting ¼ - 28 NF	3
7	607-0012	Lock Nut 1" - 8 NC.	1
8	000-1325	Yoke.	1
9	000-1753	Front Axle bolt w/ Lock Washer & Grease Fitting	2
10	000-1107	Washer - Front Axle	2
11	000-1222	King Pin Bolt	1
12	526-0010	1 ½" Countersunk Ballast Fill Plug.	2
13	000-1323	Front Drum Half (sold in pairs).	1
14	000-3057	Front Axle Bearing Spacer Set (1) .060 (1) .030 (1) .109	As Required
15	000-1058	Front Axle Grease Seal Inner & Outer	4
16	000-1057	Front Axle.	1
17	000-1292	King Pin Bolt Spacer	As Required
18	630-0009	Cotter Pin	1
19	615-5001	Soc. Head Set Screw.	4
20	000-2014	Grease Seal – King Pin	1
21	000-2015	Washer – King Pin	1

**REAR DRUM ASSEMBLY
B155**

Item No.	Part No.	Description	Qty.
1	000-6233	Mounting Ring – Vibe. Side	1
2	105-0034	Vibe. Motor.	1
3	230-0057	Coupling - Complete	1
4	325-0011	Rubber Mount	8
5	000-2527	Mfg. Plate – Vibe. Motor.	1
6	366-0001	Snap Ring - External	1
7	366-0002	Snap Ring – Internal	1
8	300-0031	Bearing Axle	1
9	000-2524	Bearing Housing Axle – Vibe Side.	1
10	000-2545	Bearing Housing – Vibe Side.	1
11	370-0008	Grease Fitting	1
12	300-0034	Bearing – Vibe Shaft	1
13	365-0074	Grease Seal	2
14	366-0003	Snap Ring - Internal.	1
15	000-6210	Rear Drum	1
16	000-6209	Vibratory Shaft	1
17	300-0033	Bearing w/Housing	1
18	000-6219	Drive Plate	1
19	105-0031	Drive Motor w/Brake (SAE Ports).	1
20	000-6229	Drive Motor Mount	1
	365-0073	Seal Kit for 105-0031	

**B155 DRUM ASSEMBLY II
S/N 1551242 & UP 4/06**

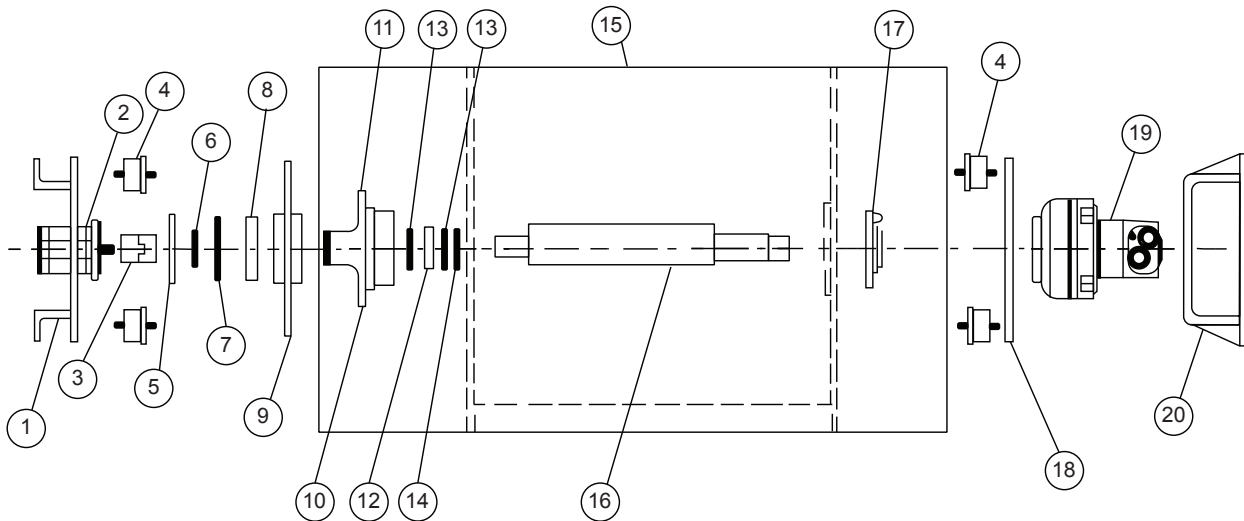

DRUM SPRAY SYSTEM – B155

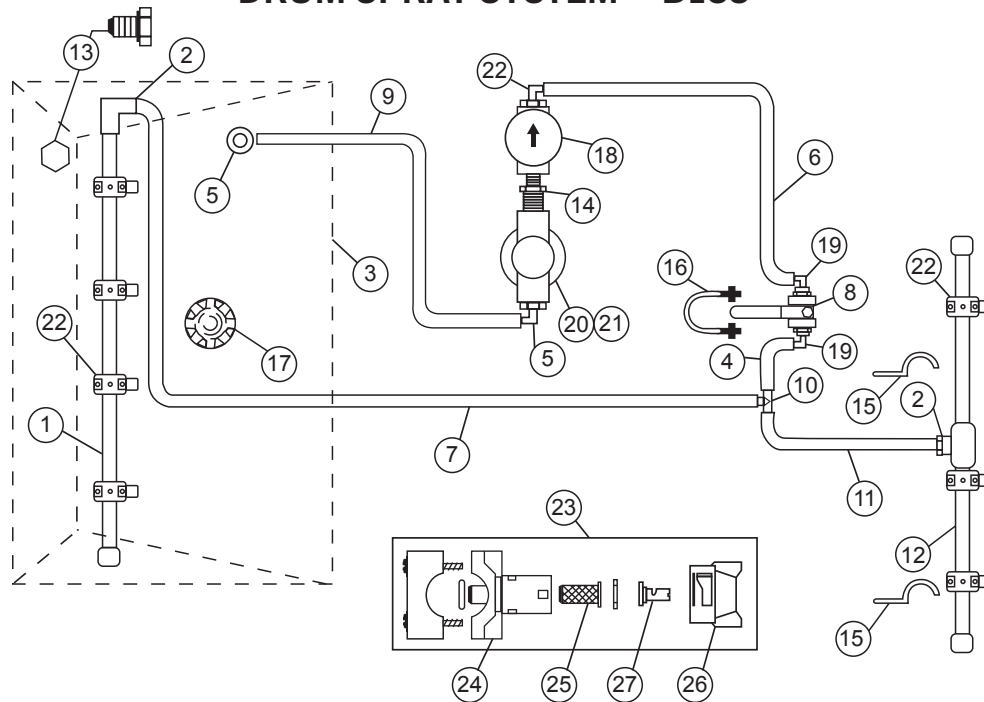

Item No.	Part No.	Description	Qty.
1	000-2147	Rear Spray Bar	1
2	540-0002	Adapter, Straight Poly	2
3	000-1402	Water Tank	1
4	424-0003-3	Water Hose, 1/2" I.D. x 3" Lg.	1
5	524-0003	Adapter, 90° Poly	2
6	424-0003-9	Water Hose, 1/2" I.D. x 9" Lg.	1
7	424-0003-32	Water Hose, 1/2" I.D. x 32" Lg.	1
8	530-0001	1/2" Bronze Ball Valve	1
9	424-0003-12	Water Hose, 1/2" I.D. x 12" Lg.	1
10	543-0003	Adapter, Tee Poly	1
11	424-0003-66	Water Hose, 1/2" I.D. x 66" Lg.	1
12	000-2146	Front Spray Bar	1
13	546-0002	Plug, 3/4" PVC	1
14	540-0004	Adapter, Straight Poly	1
15	645-0008	Clamp	2
16	645-0019	U-Bolt for Ball Valve	1
17	350-0020	Vented Water Cap w/chain	1
18	338-0041	Water Pump	1
19	542-0002	Adapter, 90° Poly	2
20	338-0020	Strainer, System	1
21	338-0031	Screen, Replacement for 338-0020	1
22	542-0004	Adapter, 90° Poly	1
23	338-0035	Complete Spray Nozzle Assembly	7
NOZZLE ASSEMBLY CONSISTS OF:			
24	338-0011	Base, Spray Nozzle	1
25	338-0013	Strainer, Spray Nozzle	1
26	338-0012	Cap & Gasket, Spray Nozzle	1
	645-0063	Hose Clamp	10
27	338-0010	Spray Tip (Brass)	7

ELECTRICAL SCHEMATIC - W/ HONDA GX630

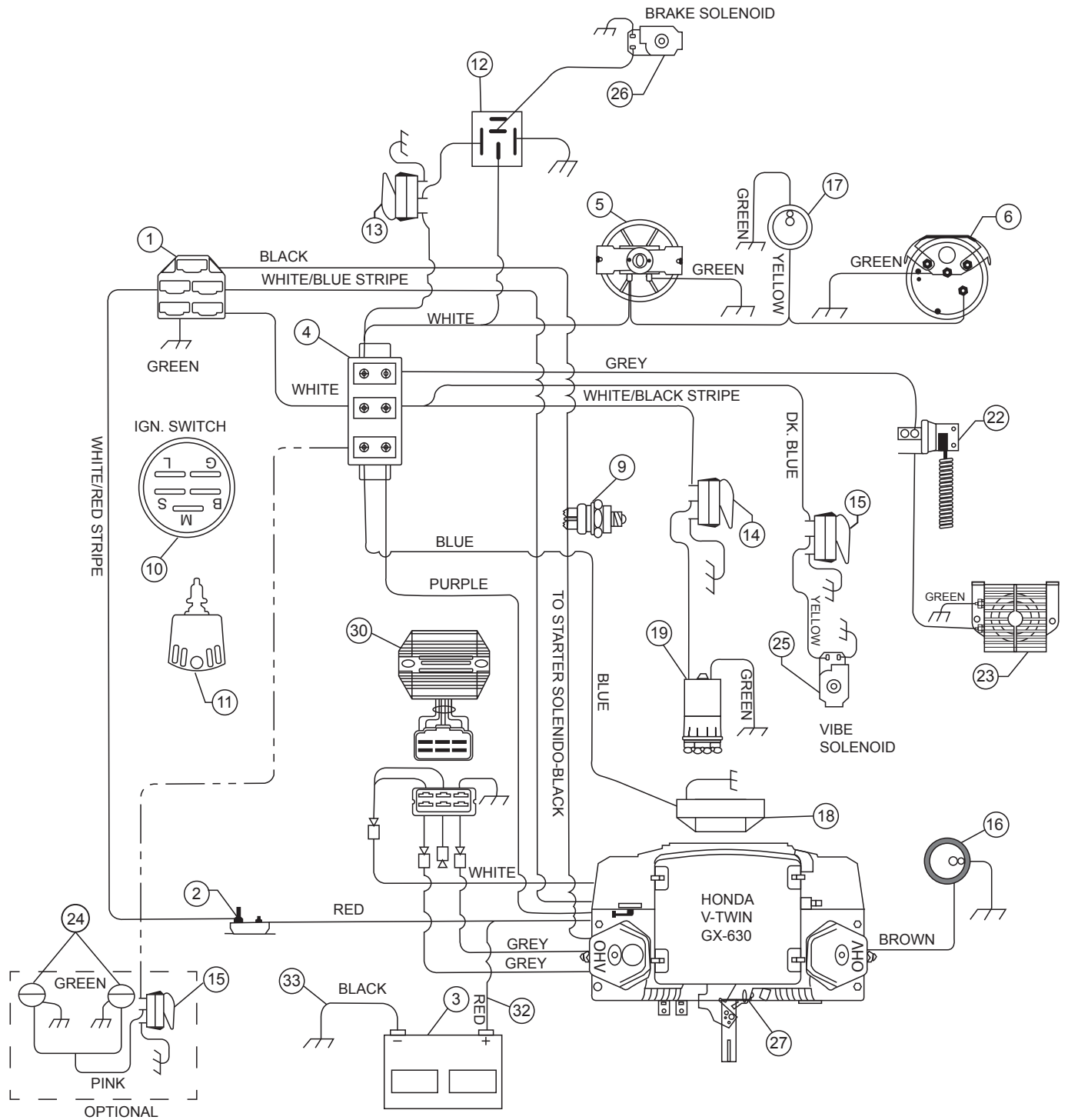

ELECTRICAL SYSTEM - W/ HONDA GX630

Item No.	Part No.	Description	Qty.
1	335-0074	Connector – 5way (1) at Key Switch	1
2	335-0063	Circuit Breaker, 30 amp (Under Dash)	1
3	335-0267	Battery, 12 volt.	1
4	335-0021	Terminal Block (Under Dash)	1
5	375-0001	Hourmeter	1
6	375-0013	Voltmeter	1
7	375-0009	Fuel Gauge (not shown)	1
8	375-0022	Fuel Sender (not shown)	1
9	335-0013	Switch, Neutral Start (at Control Lever)	1
10	335-0311	Switch, Ignition 5 pole	1
11	335-0312	Key, Ignition (set of 2)	
12	335-0291	Relay, Reverse Polarity	1
13	335-0285	Switch, Rocker (Brake) (Red)	1
14	335-0294	Switch, Rocker (Drum Spray System) (Blue).	1
15	335-0286	Switch, Rocker (Vibrator) (Work Lights).	1
16	335-0105	Light, Red Indicator (Low Oil)	1
17	335-0019	Light, Green Indicator (Run Light)	1
18	335-0307	Fan, Electric (Mounted on cooler)	1
19	338-0041	Water Pump (Drum Spray System)	1
20	335-0207	Fuse, 10 amp Spade Fuse (OPTIONAL) not shown	1
21	335-0177	Fuse Holder (OPTIONAL) not shown.	1
22	335-0094	Switch, Back-up Alarm	1
23	335-0265	Alarm, Back-up	1
24	335-0172	Work Lights (OPTIONAL).	2 or 4
25	110-0085	Coil, Vibe Control System Valve	1
26	110-0087	Coil & Valve, Brake	1
27	200-0388	Engine, Honda GX630.	1
28	335-0287	3 Switch Mounting Panel (not shown)	1
29	335-0284	Plug-mounting Panel (not shown)	As required
30	200-0409	Regulator	1
31	200-0410	Solenoid, Start Honda (not shown)	1
32	335-0289	Positive Battery Cable	1
33	335-0288	Negative Battery Cable	1
34	000-6246	Wire Harness (Honda GX630).	1

ELECTRICAL SCHEMATIC - KUBOTA Z602 DIESEL

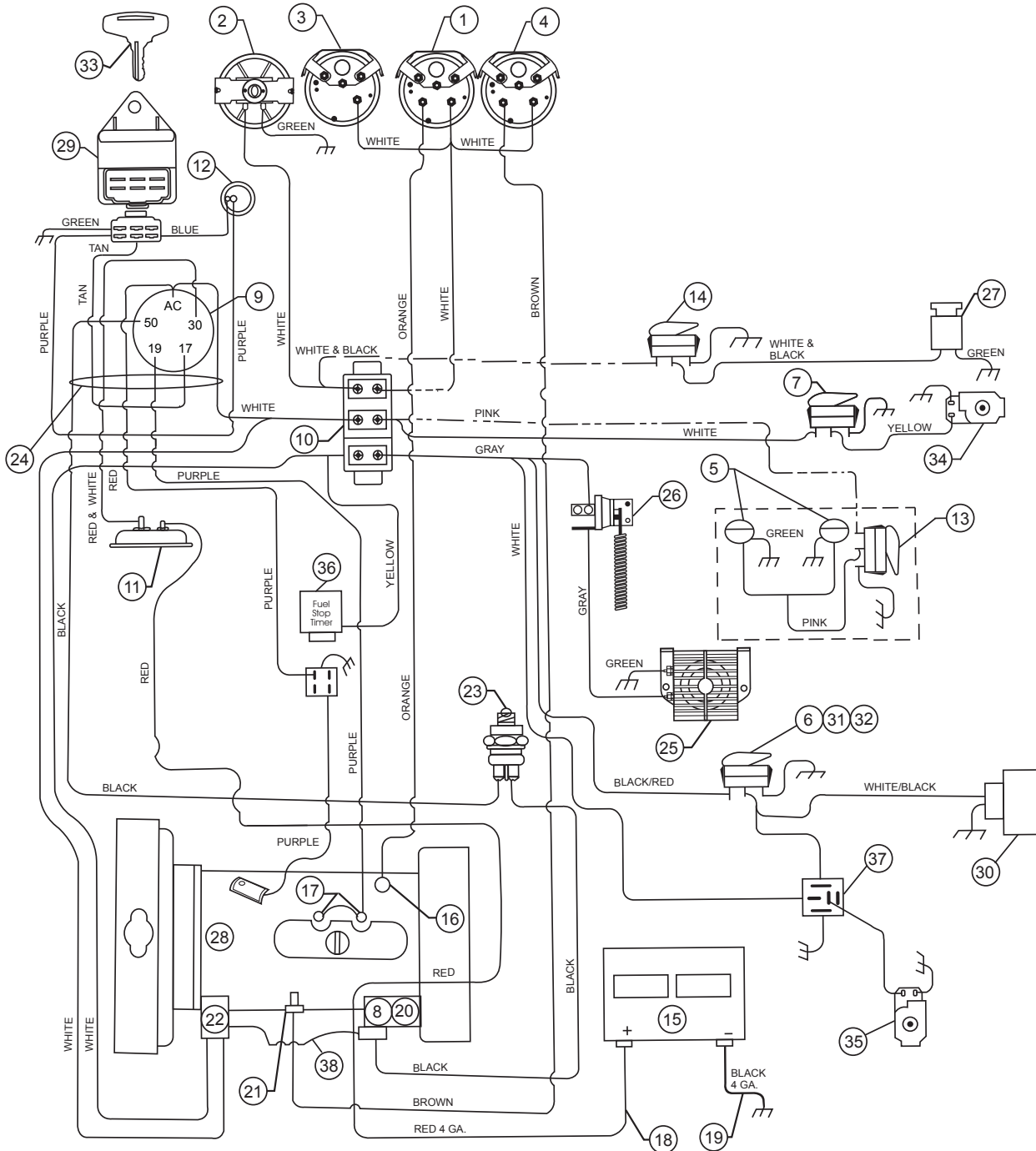

ELECTRICAL SYSTEM - w/Kubota Z602 Diesel

Item No.	Part No.	Description	Qty.
1	375-0003	Water Temp Gauge	1
2	375-0001	Engine Hour Meter	1
3	375-0013	Voltmeter	1
4	375-0023	Oil Pressure Gauge	1
*	375-0009	Fuel Gauge (not shown)	1
*	375-0022	Fuel Sender (not shown)	1
5	335-0172	Work Lights - OPTIONAL	2 or 4
6	335-0285	Rocker Switch (Brake)(Red)	1
7	335-0286	Rocker Switch (Vibe Control System)	2
8	207-0049	Starter – Kubota Z602	1
9	207-0008	Ignition Switch - Kubota	1
10	335-0021	Terminal Block (Under Dash)	1
11	335-0063	30 amp Circuit Breaker	1
12	207-0030	Glow Plug Indicator Light (Kubota)	1
13	335-0286	Switch, Rocker (Work Lights) OPTIONAL	1
14	335-0294	Switch, Rocker (Drum Spray System)(Blue)	1
15	335-0267	Battery, 12 volt.	1
16	375-0004	Water Temp Sender	1
17	207-0034	Glow Plug.	2
18	335-0289-38	(POS) Battery Cable (Red)	1
19	335-0288-28	(NEG) Battery Cable (Black)	1
20	207-0019	Solenoid, Engine (Kubota)	1
21	375-0024	Oil Pressure Sender	1
22	207-0053	Alternator (Kubota) Dynamo Assy	1
23	335-0013	Neutral Start Switch	1
24	000KD617	Beuthling Wiring Harness (Diesel Engine Only)	1
25	335-0323	Back Up Alarm.	1
26	335-0094	Switch, Back Up Alarm	1
27	338-0041	Water Pump (Drum Spray System)	1
28	205-0295	Kubota Diesel Engine Model Z602	1
29	207-0028	Lamp Timer For Glow Plugs (Kubota)	1
30	335-0121	Brake Alarm - OPTIONAL	1
31	335-0287	3 Switch Mtg. Panel (not shown)	1
32	335-0284	Mtg. Panel Plug (not shown)	As Req'd
33	335-0133	Key – Ignition (Set of 2) (Kubota)	1
34	110-0093	Coil, Vibe Control System Valve	1
35	110-0087	Coil & Valve - Brake	1
36	207-0055	Fuel Stop Solenoid Timer	1
37	335-0291	Relay (Reverse Polarity)	1
38	335-0320	Cable, Starter to Alternator	1

**Please Check Engine Serial & Spec Numbers
Before Ordering Parts**

KUBOTA 602 ENGINE

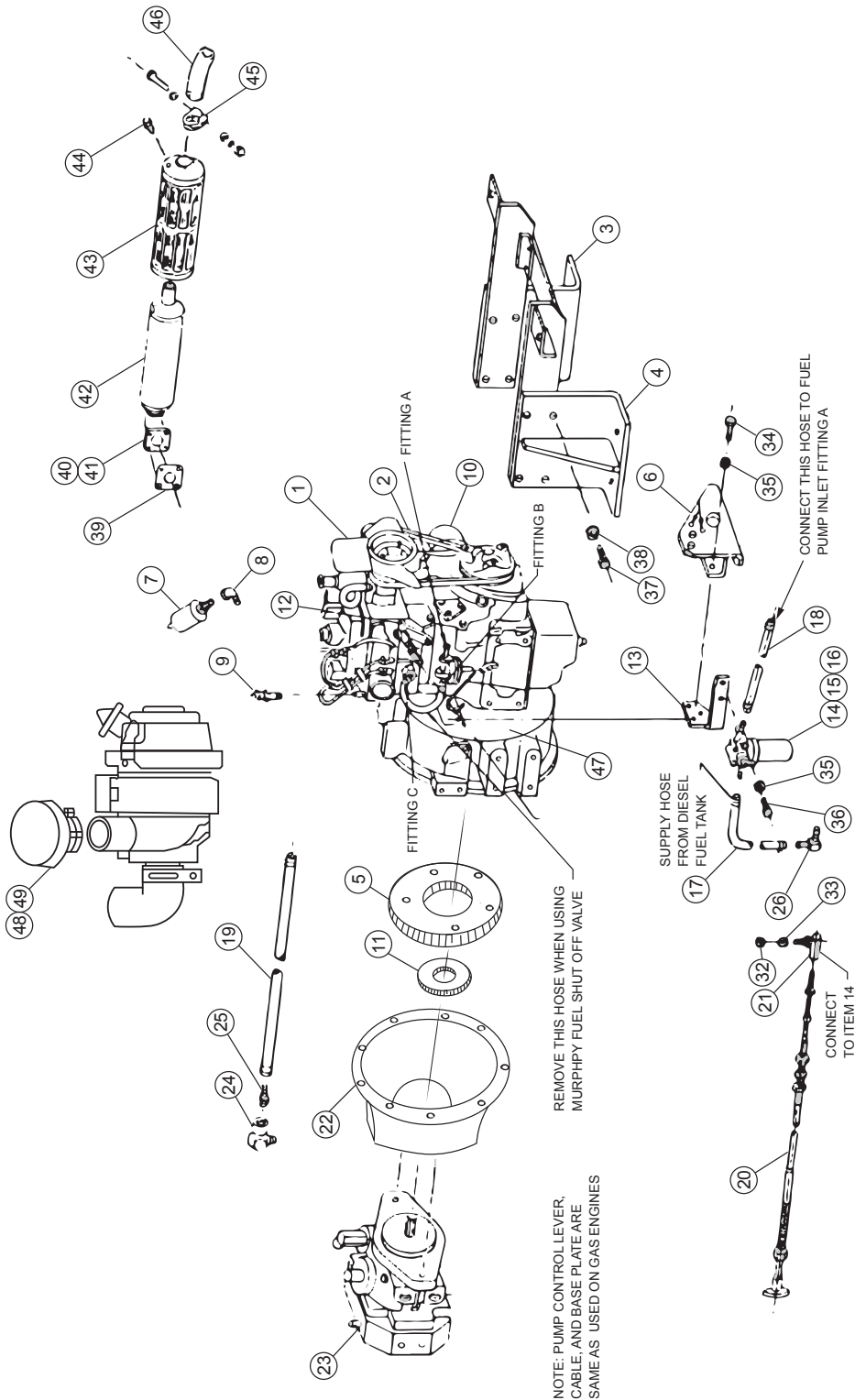

KUBOTA Z602 DIESEL ENGINE COMPONENTS

Item No.	Part No.	Description	Qty.	Item No.	Part No.	Description	Qty.
1	205-0335	Fan Blade	1	38	610-1009	10mm Lock Washer	8
2	235-0054	Fan Belt	1	39	205-0065	Gasket, Muffler	1
3	000-KD065	Engine Bracket - Left Hand	1	40	205-0066	Cover, Muffler Flange L.H. NOT SHOWN	1
4	000-KD063	Engine Bracket - Right Hand	1	41	205-0067	Cover, Muffler Flange R.H. NOT SHOWN	1
5	230-0036	Nylon Flange	1	42	000KD077	Muffler Only (ALTERED)	1
6	000-KD068	Bracket For Throttle	1	43	205-0068	Cover, Muffler	1
7	375-0024	Sender, Oil Pressure	1	44	205-0069	Bolt	1
8	501-0012	Adapter 45°, 1/8 28 BPT Male x 1/8 27 Female	1	45	397-0011	Clamp	1
9	375-0010	Sender, Water Temperature	1	46	205-0070	Muffler Pipe	1
10	205-0010	Oil Filter	1	47	205-0295	Engine Kubota Z602	1
11	230-0037	Splined Hub	1	48	205-0254	Air Cleaner- Assy. w/Element (plastic)	1
12	205-0006	Engine Stop Lever	1	49	205-0246	Element - Air Cleaner	1
13	000-KD009	Bracket, Fuel Filter	1				
14	205-0004	Cup, Fuel Filter	1				
15	205-0046	0-Ring, Fuel Filter Cup	1				
16	205-0011	Element, Fuel Filter	1				
17	432-0001-27	5/16" Fuel Line Hose x 27" Lg. (From Tank)	1				
18	432-0001-14	5/16" Fuel Line Hose x 14" Lg. (To Fuel Pump Inlet)	1				
19	420-0001-25	3/16" Fuel Line Hose x 25" Lg. (Return)	1				
20	315-0014	Throttle Cable	1				
21	645-0026	Ball Joint	1				
22	230-0042	Housing, Hydraulic Pump Mounting Plate	1				
23	100-0036	Pump, Propel SEE HYDRAULIC DIAGRAM	1				
24	502-0014	Adapter, 90° 1/4" NPT Male x 1/4" NPT Female	1				
25	500-0061	Adapter, Straight 1/4" NPT x 3/16" Barb	1				
26	502-0021	Adapter, 90° 1/4" NPT x 5/16 Barb	1				
32	605-0015	1/4" N.F. Hex. Nut	1				
33	625-0003	1/4" Lock Washer	1				
34	610-1002	8mm x 1.25 x 20mm H.H.C.S.	4				
35	610-1017	8mm Lock Washer	6				
36	610-1025	8mm x 1.25 x 65mm H.H.C.S.	2				
37	610-1001	10mm x 1.25 x 35mm H.H.C.S.	8				

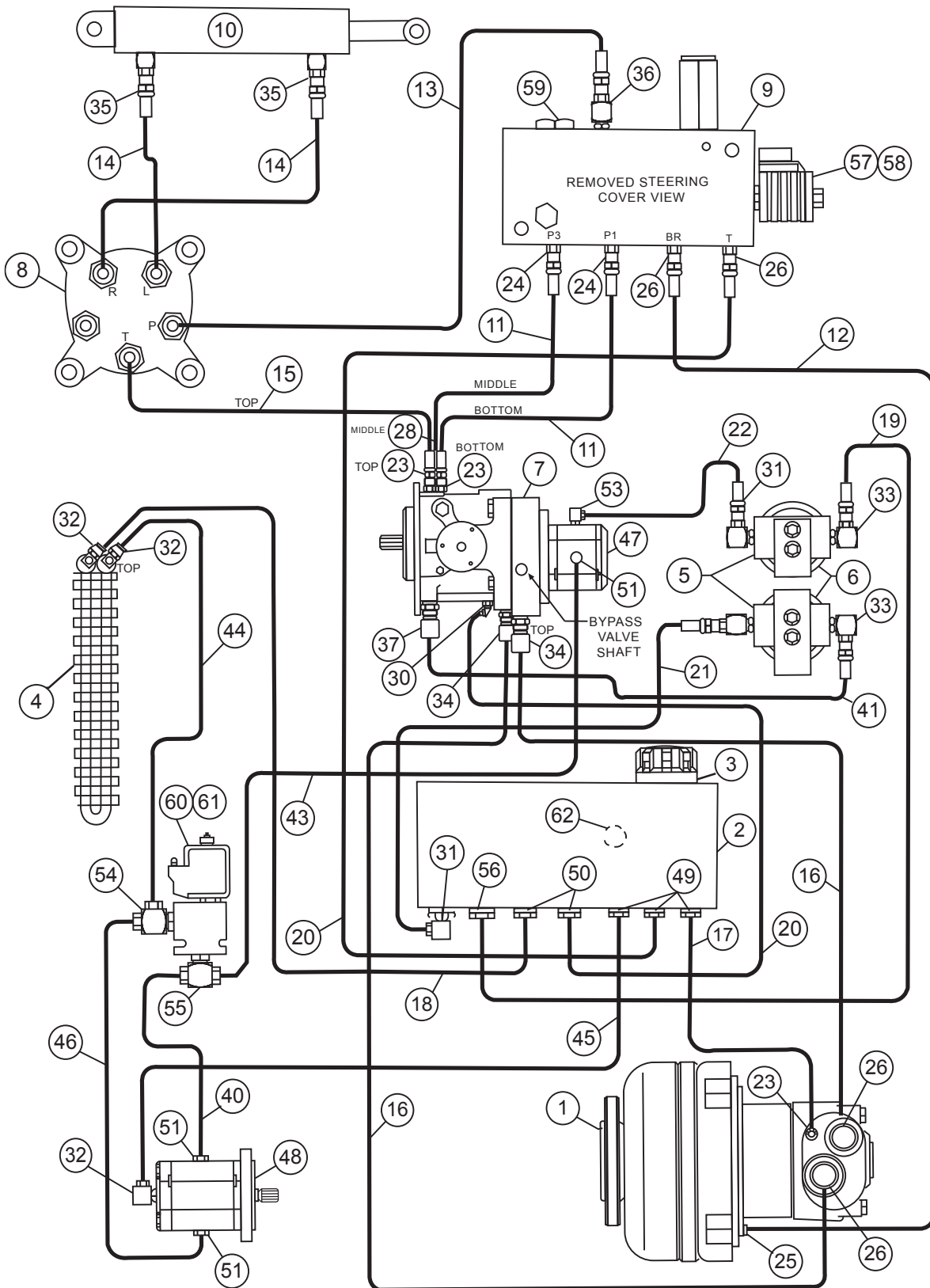

⚠ OPERATION WARNING

NORMAL OPERATION (CLOSED)
 FREEWHEEL (OPEN)

EQUIPPED WITH TRANSMISSION BY-PASS VALVE
 NORMAL OPERATION - CLOSE VALVE CW (CLOCKWISE)
 FREEWHEEL - OPEN VALVE 180DEGREE CCW (COUNTER CLOCKWISE)

BEUTHLING MFG. CO. 3003/001

HYDRAULIC SYSTEM - B155

Item No.	Part No.	Description	Qty.
1	105-0031	Drive Motor w/Brake - SAE Version	1
2	000-6222	Tank, Hydraulic Oil	1
3	350-0002	Fill Cap w/Screen	1
4	125-0003	Heat Exchanger	1
5	130-0003	Filter Head	2
6	130-0002	Filter Element	2
7	100-0036	Pump, Propel	1
8	105-0032	Motor, Steering Orbital	1
*	330-0023	Column, Steering Orbital (Not Shown)	1
9	110-0073	Manifold Package, Brake and Steering System	1
10	115-0008	Cylinder, Steering	1
11	403-0059	Hose Assembly, 3/8" I.D. x 32" Lg.	2
12	403-0060	Hose Assembly, 3/8" I.D. x 80" Lg.	1
13	403-0061	Hose Assembly, 3/8" I.D. x 20" Lg.	1
14	403-0062	Hose Assembly, 3/8" I.D. x 24" Lg.	2
15	403-0073	Hose Assembly, 3/8" I.D. x 60" Lg.	1
16	404-0077	Hose Assembly, 1/2" I.D. x 28" Lg.	2
17	423-0001-34	Hose Assembly, 3/8" I.D. x 34" Lg.	1
18	423-0001-60	Hose Assembly, 3/8" I.D. x 60" Lg.	1
19	426-0001-16	Hose Assembly, 3/4" I.D. x 16" (Diesel)	1
20	424-0001-15	Hose Assembly, 1/2" I.D. x 15" Lg.	1
21	426-0001-20	Hose Assembly, 3/4" I.D. x 20" Lg. (Gas and Diesel)	1
22	426-0001-10	Hose Assembly, 3/4" I.D. x 10" Lg. (Diesel)	1
23	500-0003	Adapter, Straight	3
24	500-0046	Adapter, Straight	2
25	500-0068	Adapter, Straight	1
26	500-0075	Adapter, Straight	4
28	500-0082	Adapter, Straight	1
30	501-0008	Adapter, 45°	1
31	502-0008	Adapter, 90°	2
32	502-0013	Adapter, 90°	2
33	502-0007	Adapter, 90°	2
34	502-0010	Adapter, 90°	2
35	502-0011	Adapter, 90°	2
36	502-0054	Adapter, 90°	1
37	503-0009	Adapter, Tee	1
40	404-0085	Hose Assembly, 1/2" I.D. x 28" Lg.	1
41	426-0001-14	Hose Assembly, 3/4" I.D. x 14" Lg. (Diesel)	1
43	404-0086	Hose Assembly, 1/2" I.D. x 36" Lg.	1
44	423-0025	Hose Assembly, 3/8" I.D. x 25" Lg.	1
45	423-0001-60	Hose Assembly, 3/8" I.D. x 60" Lg.	1
46	404-0086	Hose Assembly, 3/4" I.D. x 36" Lg. (Diesel Only)	1
47	100-0028	Pump, Vibe	1
48	105-0040	Motor, Vibe	1
49	502-0055	Adapter, 90°	1
50	502-0031	Adapter, 90°	3
51	502-0013	Adapter, 90°	1
52	503-0018	Adapter, Tee	1
53	503-0015	Adapter, Tee	1
54	110-0095	Valve Package - Vibe Control	1
55	502-0008	Adapter, 90°	1
56	500-0035	Adapter, Straight	1
57	110-0072	Valve, Brake Pressure Relief	1
58	110-0077	Coil, Brake Valve Complete	1
59	110-0087	Coil & Cartridge for Brake Valve	1
60	110-0094	Cartridge Valve (Vibe System)(Part of 110-0095)	1
61	110-0093	Coil Only (Vibe System)(Part of 110-0095)	1
62	135-0017	Sight Gauge	1

* Item Not Shown

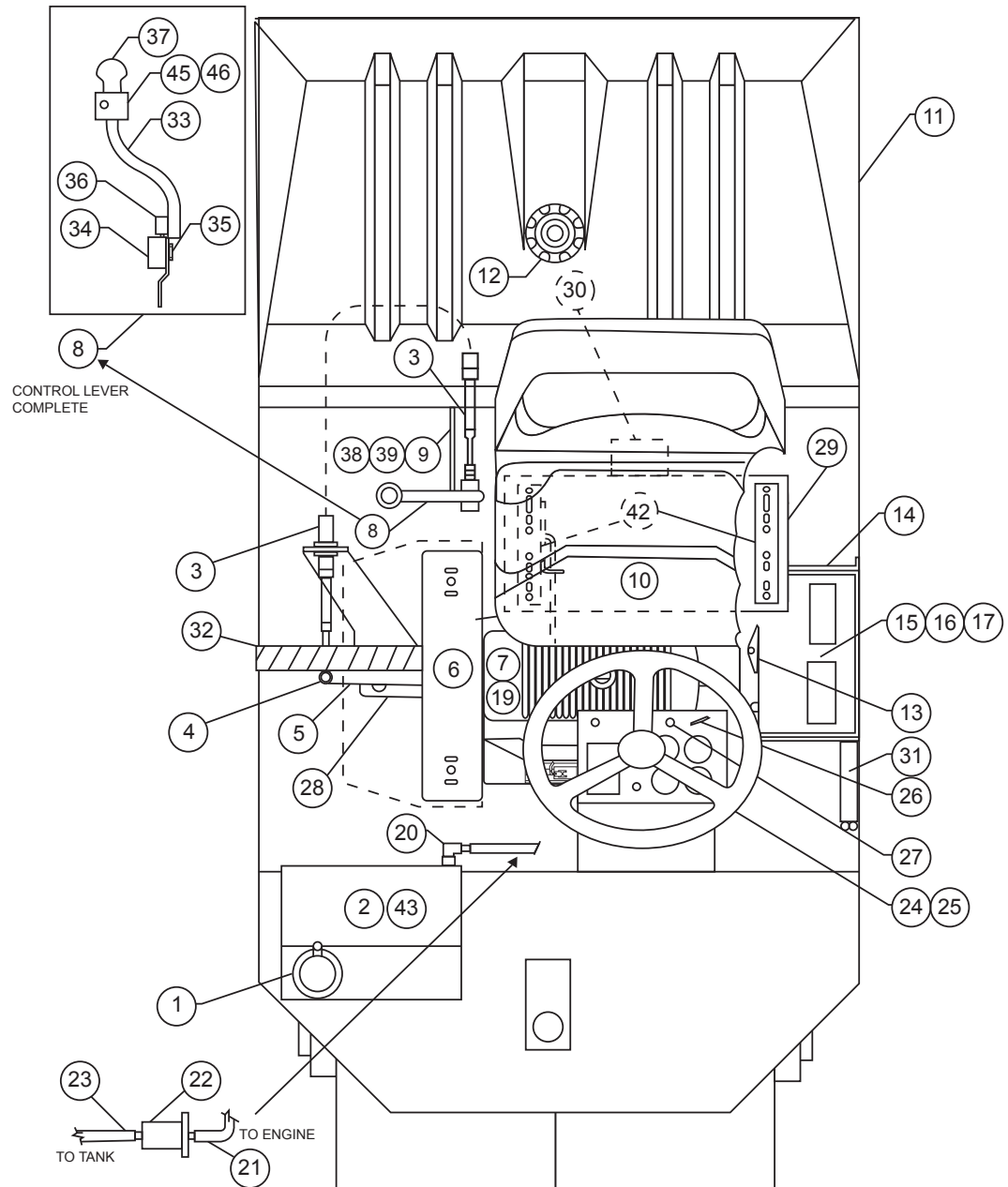

MISCELLANEOUS COMPONENTS

Item No.	Part No.	Description	Qty.
1	350-0033	Fill Cap Complete, Fuel (Ser.# 1551299 and up) Gasoline	1
1	350-0002	Fill Cap Complete, Fuel Gasoline and Diesel	1
2	000-2003	Fuel Tank	1
3	315-0010	Control Cable, Pump	1
4	645-0022	Ball Joint	2
5	000-3020	Control Lever, on Pump	1
6	200-0431	Muffler - Honda GX630	1
7	205-0295	Engine - NOT SHOWN - Kubota Diesel Z602	1
8	000-1441	Control Lever, Forward & Reverse Complete Assembly	1
9	000-1010	Control Cable Bracket, Upper	1
10	395-0001	Seat w/Slides	1
11	000-1402	Water Tank, Poly	1
12	350-0020	Water Cap w/Chain	1
13	385-0074	Battery Hold Down.	1
14	000-1405	Battery Tray	1
15	335-0267	Battery 12 Volt	1
16	335-0288	Battery Cable - Negative - NOT SHOWN	1
17	335-0289	Battery Cable - Positive - NOT SHOWN - Kohler CH18S	1
19	500-0083	Adapter, 1/4 - 18 Male x 1.4 - 18 Female NPT	1
19	200-0388	Engine, Honda GX630.	1
*	200-0400	Filter, Engine Oil - Honda GX630.	1
*	200-0401	Filter, Engine Air - Honda GX630.	1
*	200-0402	Engine, Fuel - Honda GX630.	1
20	502-0014	Adapter, 90°.	1
21	420-0001-3	Fuel Line 1/4"x 3" Lg. (Filter to Engine)	1
22	200-0014	Fuel Filter - Kohler	1
*	345-0001	Pump Mount - NOT SHOWN	1
*	230-0007	Chain Coupling - NOT SHOWN (Honda).	1
23	420-0001	Fuel Line 1/4"	1
24	330-0024	Steering Wheel.	1
25	330-0025	Cap, Steering Wheel	1
*	330-0027	Spinner Knob - Steering Wheel - OPTIONAL	1
26	315-0022	Throttle Cable w/Tee Handle (Kohler and Honda Engine)	1
27	315-0001	Choke Cable (Kohler and Honda Engine).	1
28	000-3021	Pump Control Base Plate.	1
29	000-1240	Seat Base.	1
30	335-0265	Back Up Alarm	1
31	125-0003	Heat Exchanger - Hydraulic	1
32	000-3158	Exhaust Pipe Honda GX630 (Directs Exhaust Outside Side Plate).	1
33	000-3037	Control Lever Only.	1
34	000-1438	Mount - Control Lever	1
35	000-1440	Bolt - Adjusting	1

* Item Not Shown

MISCELLANEOUS COMPONENTS (CONTINUED)

Item No.	Part No.	Description	Qty.
36	310-0005	Plunger - Neutral Detent	1
37	350-0031	Knob - Soft Plastic	1
38	335-0094	Back Up Alarm Switch	1
39	000-2138	Control Lever Stop Angle	1
42	395-0019	Seat Sides	1 Pair
*	380-0112	Complete Decal Set	1
43	530-0008	Valve, Slosh Roll-Over	1
44	000-3036	Control Lever Assy.	1
45	000-3013	Housing Vibe Switch	1
46	335-0071	Switch, Toggle	1

COVERS, RUBBER SCRAPERS & COCOA MATS

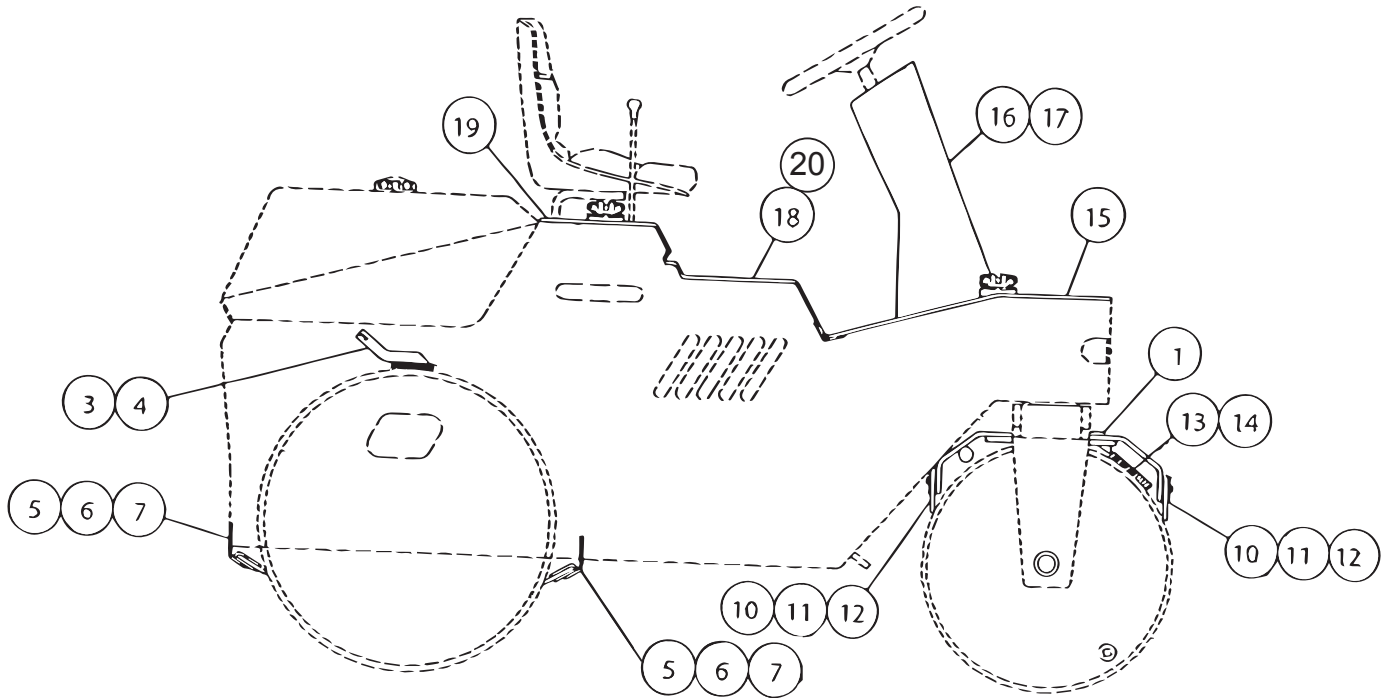

Item No.	Part No.	Description	Qty.
1	000-1416	Front Cocoa Mat Pivot Bracket	2
3	000-1293	Cocoa Mat Pan - Rear	1
4	355-0005	Cocoa Mat Rear	1
5	000-1296	Bracket - Rear Drum Scraper	2
6	000-1410	Back Up Bar - Rear Rubber Scraper.	4
7	000-1411	Rear Rubber Scraper.	2
10	000-1268	Back Up Bar - Front Rubber Scraper	4
11	000-1269	Front Rubber Scraper	2
12	000-1407	Front Scraper Arm	4
13	000-1419	Front Cocoa Mat Pan.	1
14	355-0001	Cocoa Mat Front	1
15	000-2141	Front Floor Cover	1
16	000-2156	Dash Panel - NOT SHOWN	1
17	000-2142	Steering Column Cover	1
18	000-1367	Center Floor Cover w/Louvers.	1
19	000-2110	Rear Floor Cover	1
20	000-2041	Heat Deflector Shield.	1
*	380-0112	Complete Set of Decals	1

* Item Not Shown

SPECIFICATIONS

WEIGHTS

Shipping Weight 2700 lbs.
 Operating Weight (Full Ballast + Operator) 3200 lbs.

DIMENSIONS

Overall Length 77 in.
 Overall Height 62 in.
 Overall Width 40 in.
 Wheelbase 52.75 in.
 Curb Clearance 9.50 in.
 Wall Clearance 8.75 in.

CAPACITIES

Fuel (Honda/Kubota) 2.75 gal.
 Hydraulic Fluid 2.5 gal.
 Engine Oil (Honda) 1.5 qts.
 Water Tank 34 gal.

DRUMS

FRONT:

Overall Width 37 in.
 Diameter 20 in.
 Shell Thickness437 in.

REAR:

Overall Width 37 in.
 Diameter 24 in.
 Shell Thickness500 in.

STEERING

Type Hydraulic, cylinder-front drum
 Turning Radius (inside) 56 in.
 Oscillation 24° Total

DRIVE

Drive System Hydrostatic, *Internal Direct Drive*,
 Rear Drum, Single Lever, Infinitely Variable Controls
 Travel Speed 0-6 MPH
 Engine Honda GX630 Twin Cylinder
 Air Cooled, Gasoline, Electric Start, 12 Volt Battery

VIBRATION SYSTEM -REAR DRUM

Type Hydraulic Direct Drive (Vibe Shaft & Motor in Drum)
 Control On-Off Switch on Control Lever
 Frequency 2500 VPM
 Centrifugal Force 4500 lbs. @ 2500 VPM
 Total Applied Force 6550 lbs.

BRAKES

Service Hydrostatic drive provides dynamic braking
 Secondary/Parking Failsafe, Spring applied
 Hydraulically released, manual switch on console

DRUM SPRAY SYSTEM

Type Pressurized water w/electric pump &
 quick disconnect spray nozzles
 Tank Polyethylene plastic, 3" fill neck,
 cap w/safety chain rear, 34 gal. capacity
 Drum Scrapers Four adjustable, rubber
 Drum Cocoa Mats One each drum, pivoting

STANDARD EQUIPMENT

- Instrumentation Hourmeter, Voltmeter, Fuel Gauge,
 & Low Engine Oil Indicator Light
- Vandal Protection Lockable Fill Caps for
 Fuel and Hydraulic Fluid
- Seat High Back, Bucket Type Adjustable
- Safety Devices Neutral Start Switch, Back-Up Alarm,
 Failsafe Hydraulic Brake

OPTIONAL EQUIPMENT

- Kubota Diesel Engine
- Vandal Protection Package
- Work Lights
- Arm Rests
- Special Paint (Any Color)
- ROPS (Rollover Protection Structure) w/Seat Belt



B155

COMPACTOR IDENTIFICATION INFORMATION

COMPACTOR SERIAL NUMBER: _____

ENGINE, MAKE, MODEL & SERIAL NUMBER: _____

PURCHASE DATE: _____

DEALER: _____

PHONE #: _____

COMPACTOR SERVICE INFORMATION

M1-24-155

New Beuthling
465 Griffin Blvd.
Amery, WI 54001
715-263-2300